

TECHNICAL NOTE

ON-LINE COMPUTATION OF PHOTORECEPTOR SPECTRAL SENSITIVITY – A LOW-COST SOLUTION WITH A PROGRAMMABLE POCKET CALCULATOR

R. MENZEL¹, J. ERBER and U. GREGGERS¹

Institut für Tierphysiologie der Freien Universität, Berlin, West Germany
(Received 5 December 1977)

INTRODUCTION

The knowledge of the function of photoreceptors has gained much from studies of invertebrate retinæ. In particular, the determination of the spectral properties has led to new concepts of the transduction of light into biologically relevant information (e.g. Laughlin, 1976; Wasserman, 1973; Menzel, 1975). Invertebrate photoreceptors respond with graded depolarizing potentials to an increase of light intensity (Fig. 1A). The size of the receptor potentials depends on the number of light quanta absorbed. Both the wavelength and the number of absorbed quanta of the stimulating light determine the response size. The spectral sensitivity of a photoreceptor is measured by determining the number of absorbed quanta, which produce a constant receptor response for different wavelengths. To measure the spectral sensitivity of a photoreceptor, one has to stimulate the eye with different intensities of monochromatic light. As it is not always possible to measure intracellular responses of a cell over many minutes, the calculation of spectral sensitivity is often difficult or even impossible.

The calculation of spectral sensitivity

The relation between the response of a cell and the intensity of the stimulus (measured in emitted quanta) can be quantified in response/intensity functions (R/I curves); examples are given in Fig. 1. Over a certain range, the response increases linearly with a logarithmic increase of intensity; this is the linear range between the lower and upper threshold. Usually the R/I curve is measured for one wavelength, which can be achieved by stimulating the cell with about ten different intensities. To reduce statistical variations of the measurement, the stimulations have to be repeated a certain number of times. For the other wavelengths one usually measures only one response for intensities within the linear range of the R/I curve. For the calculation of spectral sensitivity one assumes that the R/I curves for different wavelengths are similar but shifted along the intensity axis. The cell responses are evaluated by measuring such response parameters as the initial peak height or the height

of the plateau (Fig. 1). The measured R/I curve can be reduced to the linear part. For this range one can calculate a regression line. The slope of this line is used to determine the cell's sensitivity for different wavelengths. It is obvious that these steps are timeconsuming and that they incorporate a number of inaccuracies, which influence the determination of spectral sensitivity.

It is possible to automate these steps. The main difficulties are fast A/D conversion of the cell response, the measurement of defined peaks and plateaus, and the mathematical definition of the R/I curve. If a laboratory computer with enough storage facilities is available, there should be no problem for an electrophysiologist to program such a computer. However, there is an alternative possibility, which does not need a laboratory computer and no knowledge of a computer program language.

A new technique of computing spectral sensitivities

The basic idea for a simple computation of spectral sensitivity is to measure complete R/I curves for all wavelengths of the stimulating light very rapidly by using a logarithmic neutral density wedge with a range of 3 log units of attenuation. Rotating this wedge in the light beam makes it possible to register a complete R/I curve within 250 msec. A certain level of receptor response has to be defined – the so-called constant response level. When this constant level is reached, an analog comparator generates a trigger impulse. The BCD coded density value of the neutral density wedge is read; at the same time the calibration factor of the stimulus wavelength is read. The two values are then multiplied. The logarithm of the inverse of this value is equal to the logarithmic sensitivity of the photoreceptor for the wavelength used, and is plotted. Figure 1(B) shows results of this calculation and typical cell responses. The actual calculation of spectral sensitivity is reduced to a few steps:

1. Read x : = relative intensity of the neutral density wedge (density value)
2. Read k : = calibration factor, which is different for each wavelength
3. $k * x$ = relative quanta of the stimulus to reach the constant response level
4. $s = 1 / k * x$ = sensitivity
5. $\log s$ = logarithmic sensitivity
6. write s = sensitivity
7. write λ = stimulus wavelength

Please send reprint requests to: R. Menzel, Institut für Neurobiologie der Freien Universität Berlin, 14195 Berlin, Königin-Luise-Str. 28-30.

This work was supported by the Deutsche Forschungsgemeinschaft, grant Me 365/5

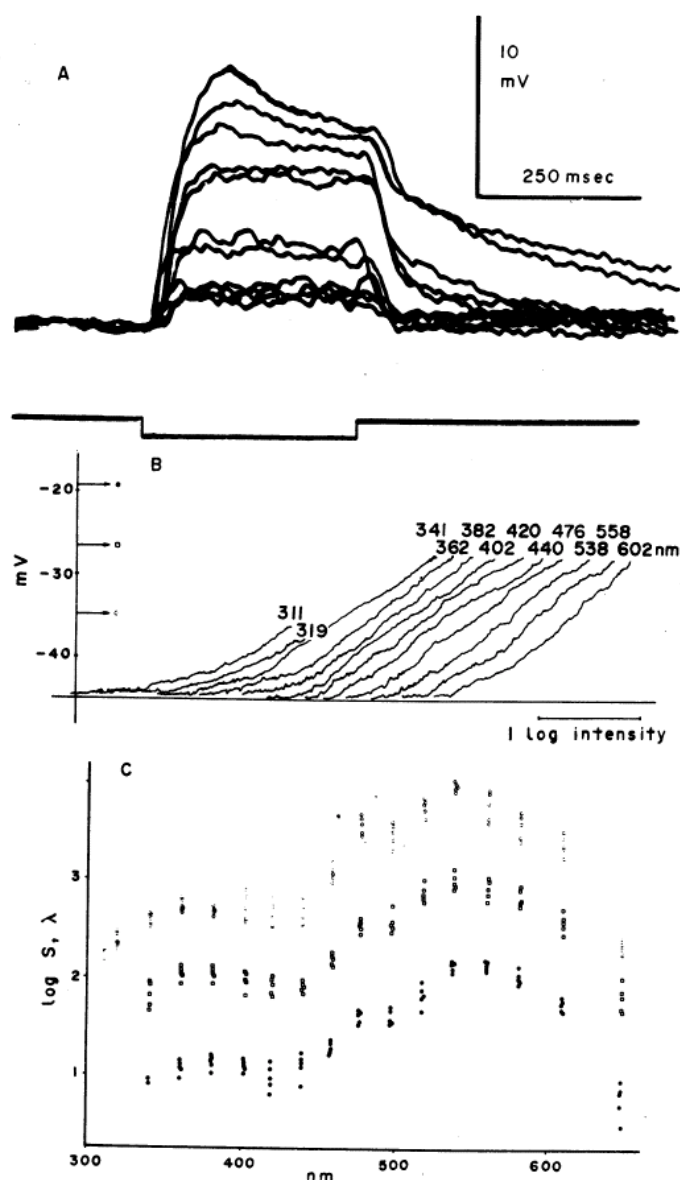

Fig. 1. A : Intracellular responses of photoreceptors to light flashes in the worker bee eye. The 300 msec light flashes (lower trace) are presented at 10 different intensities; the responses are superimposed on the screen. B: Intracellular responses of a bee photoreceptor to ramp functions of monochromatic light of various wavelengths (311 nm – 602 nm). The circular neutral density wedge produces a logarithmic modulation of light intensity over 3 log units within 250 msec. The responses are arbitrarily shifted along the horizontal intensity axis. The ordinate gives the absolute membrane voltage in mV. Three different constant response levels are indicated; these values are used to calculate the spectral sensitivities of Fig. 1C. C: The result of an experiment with bee photoreceptors demonstrating the on-line computation of spectral sensitivity as described in the text. 15 spectral runs for the three different response levels of Fig. 1B were carried out with one cell.

A pocket calculator which is programmable and which has the functions 1 – 7 can easily solve this problem when it is modified to read x and k and to plot s and λ .

Hardware requirements

The main modification of the pocket calculator is the connection of two input/output shift registers to the serial bidirectional bus between processor chip

and memory chip. It is necessary to add a simple detecting device for the instructions used by the calculator to control the data flow between the processor and two of the seven internal data registers. With this modification it is possible to control reading and writing of the two additional input/output registers without interfering with the normal functioning of the pocket calculator. The normal register transfer time of 250 msec and the resolution of the pocket calculator

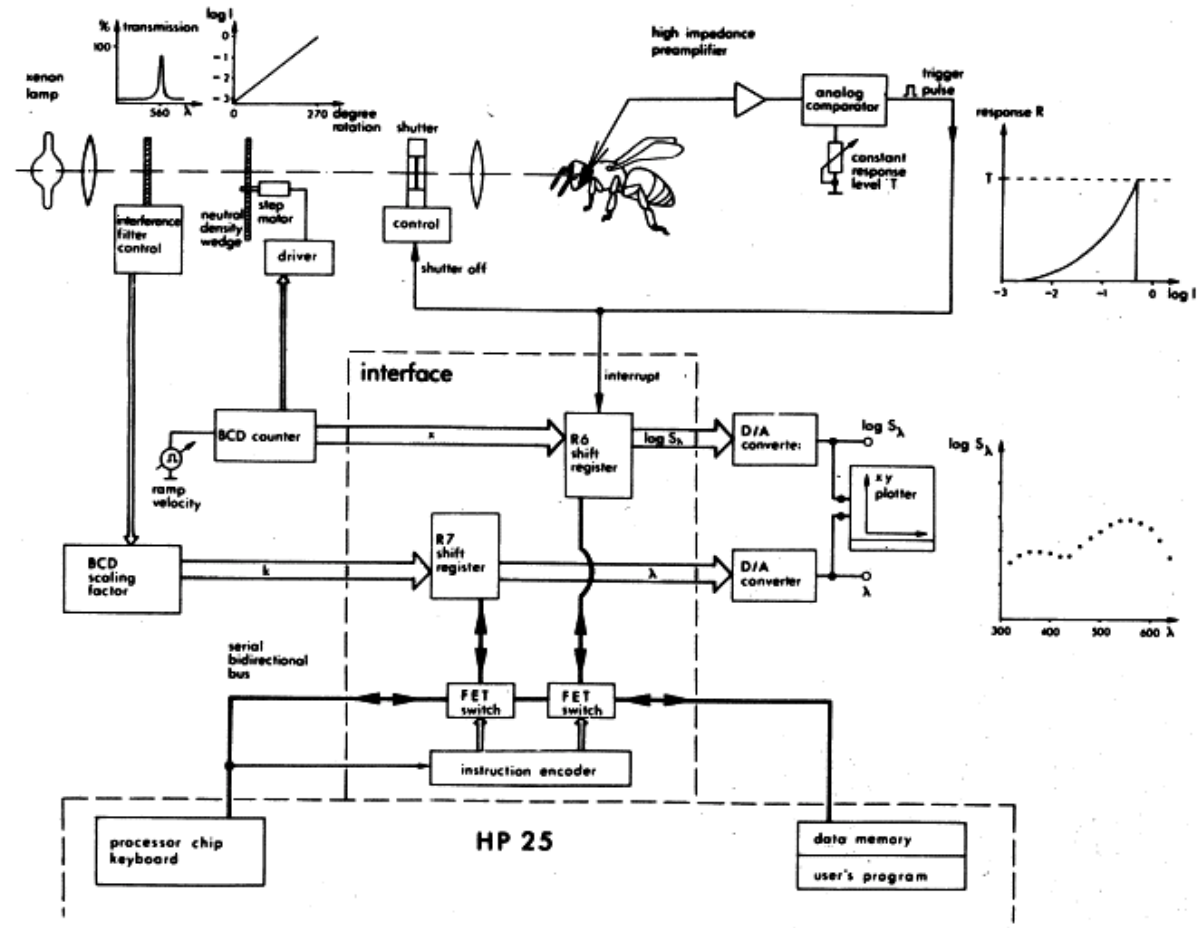

Fig. 2. Set-up used for on-line analysis of spectral sensitivity. The stimulation is achieved with a Xenon lamp, narrow-banded interference filters, a circular neutral density wedge and a shutter. An analog comparator generates a trigger pulse when the adjustable constant response level (T) is reached. This pulse closes the shutter and enables reading of the BCD scaling factor (k) of each individual interference filter and the BCD coded relative intensity (x) of the neutral density wedge. The interface, which was added to the programmable pocket calculator (Hewlett Packard HP 25) contains two shift-registers, two FET switches and an instruction encoder. The registers R6 and R7 are also used for writing the logarithmic sensitivity ($\log S_{\lambda}$) and the corresponding wavelength (λ). (All information necessary to build the shift registers, FET switches and instruction encoder will be sent on request.)

are not changed by this manipulation. As single measurements of the cell's response are taken about every 3 – 5 sec, there is no difficulty in reading, calculating and plotting the data, even with a slow pocket calculator during the interval between two successive measurements. The plotting of data is limited to 10 data points. With software instructions it is possible to control the offset and the range of the output, so that the full resolution can be used for plotting. The difficulty of fast A/D conversion is overcome by reading the digital intensity value of the neutral density wedge, the processing of analog data is reduced to the action of an analog comparator which generates the trigger signal for reading digital values. Figure 2 shows the principle of this on-line measuring system. (Upon request, a copy of the wiring diagram and the program for $S(\lambda)$ calculation will be sent with the reprint of this paper.)

DISCUSSION

The new device for calculating and measuring online spectral sensitivities of photoreceptors has several important advantages compared to methods previously used. Although the most important factor is the short duration of the measurements, this aspect, at least for photoreceptors, is of minor interest to us. The rapid computation of spectral sensitivity gives

the experimenter the possibility to carry out selective experiments, e.g. staining of cells, which are rarely encountered, or chromatic adaptation. By measuring several times within a few minutes the spectral sensitivity of a single cell one has the data for an extensive statistical analysis (Fig. 1C). The evaluation of stored responses makes it possible to analyse parameters such as the signal to noise ratio of an R/I curve. By defining several different levels of constant response level it is possible to test the relationship between the spectral properties of a cell and the criterion used to calculate sensitivity. The measuring principle is applicable to analyses of higher visual interneurons, which respond with graded potentials to changes of illumination. As the system is of low cost compared to general purpose laboratory computers, there are no difficulties in duplicating it and using it in several set-ups for quite different problems.

This work was supported by the Deutsche Forschungsgemeinschaft, grant Me 365/5.

REFERENCES

- Laughlin S. B. (1976) The sensitivities of dragonfly photoreceptors and the voltage gain of transduction. *J. comp. Physiol.* **111**, 221 – 247.
- Menzel R. (1975) Color receptor in insects. In *The Compound eye and Vision in Insects* (Edited by Horridge G. A.), pp. 121 – 153. Clarendon Press, Oxford.
- Wasserman G. S. (1973) Invertebrate color vision and the tuned receptor paradigm. *Science* **180**, 268 – 275.