

Memory dynamics and foraging strategies of honeybees

Uwe Greggers and Randolf Menzel

Institut für Neurobiologie, Freie Universität Berlin, Königin-Luise-Strasse 28/30, 14195 Berlin, Germany

Received January 17, 1992 / Accepted July 3, 1992

Summary. The foraging behavior of a single bee in a patch of four electronic flower dummies (feeders) was studied with the aim of analyzing the informational components in the choice process. In different experimental combinations of reward rates, color marks, odors and distances of the feeders, the behavior of the test bee was monitored by a computer in real time by several devices installed in each feeder. The test bee optimizes by partially matching its choice behavior to the reward rates of the feeders. The matching behavior differs strongly between “stay” flights (the bee chooses the feeder just visited) and “shift” flights (the bee chooses one of the three alternative feeders). The probability of stay and shift flights depends on the reward sequence and on the time interval between successive visits. Since functions describing the rising probability of stay flights with rising amounts of sucrose solution just experienced differ for the four feeders, it is concluded that bees develop feeder-specific memories. The choice profiles of shift flights between the three alternative feeders depend on the mean reward rate of the feeder last visited. Good matching is found after visits to the low-reward feeders and poor matching following departure from the high-reward feeders. These results indicate that bees use two different kinds of memories to guide their choice behavior: a transient short-term working memory that is not feeder-specific, and a feeder-specific long-term reference memory. Model calculations were carried out to test this hypothesis. The model was based on a learning rule (the difference rule) developed by Rescorla and Wagner (1972), which was extended to the two forms of memories to predict this operant behavior. The experiments show that a foraging honeybee learns the properties of a food source (its signals and rewards) so effectively that specific expectations guide the choice behavior.

Introduction

The foraging behavior of flower-visiting Hymenoptera has frequently been used in the past to examine the predictions of optimality arguments that aim to explain the choices animals make between patchily distributed food sources of different profitability (Heinrich 1975; Pyke 1978; Waddington and Holden 1979; Pyke 1984; Waddington 1985; Stephens and Krebs 1991). These experimental and theoretical studies emphasize the energetic components of the process, revealing that choice behavior is not random, but rather tends to reduce foraging time, risk and cost, leading, in general, to an optimization of relative profits. Questions relating to the mechanisms have focused on measurements of metabolic investment (Heinrich 1972, 1981, 1983; Seeley 1985; Schmid-Hempel and Wolf 1988; Wolf et al. 1989; Waddington 1990), the perception of cost and benefit (Marden and Waddington 1981; Waddington 1982, 1985; Schmid-Hempel et al. 1985; Schmid-Hempel 1987; Waddington and Gottlieb 1990) and on an analysis of the flight path of individual animals in natural or artificial arrangements of nectar sources (Pyke 1978; Waddington and Heinrich 1981; Pflumm 1984; Schmid-Hempel 1984; Schmid-Hempel et al. 1985).

The informational components of searching and decision-making behavior have been little addressed, although it has been known for a long time (Buttel-Reepen 1900; Forel 1910; Frisch 1914, 1965) that bees and wasps direct their search for food sources according not only to innate search images, but also to individual experience and – in the case of the honeybee – information transfer within the society. So far, extensive studies on learning and memory of bees (Lindauer 1963; Frisch 1965; Menzel 1985, 1987) have been performed with little reference to the natural conditions under which optimality arguments become relevant. On the other hand, those studies which consider learning behavior under natural conditions (Heinrich 1984) provide only qualitative and anecdotal evidence for the notion that the choice process is guided by the actual informational status of the ani-

mal. In a recent study on bumblebees (Real 1991) a first attempt was made to apply computational rules to optimizing strategies, but the dynamics of the learning processes were neglected.

A mechanistic and functional understanding of the optimizing processes requires an understanding of both the energetic and the informational components, since a foraging animal collects food (energy, energetic benefits per invested costs) and information simultaneously. Both behavioral ecology and animal learning studies can contribute to such an analysis (Kamil and Roitblat 1985).

Optimizing strategies can be studied by a behavioral analysis of the choice process. There are two major strategies by which a foraging pollinator optimizes its choice:

(1) *Matching behavior*, as found in many animals, was described formally by Herrnstein (1970) and on an experimentally extended basis by Staddon (1983). Matching behavior leads to a proportional relationship between food offer and food intake, i.e. the animal chooses more than one food source and prefers the more efficient ones. (2) In contrast, another behavioral strategy is to maximize food intake by choosing exclusively the food source with the best cost/reward ratio (*maximization*).

For flower-visiting insects, matching behavior has been described as "majoring and minoring", and the dominant strategy applied by bumblebees has been interpreted as such (Heinrich et al. 1977), whereas maximizing behavior is known for the honeybee with its well-documented flower constancy (von Frisch 1965).

It will be shown in this study that the honeybee uses matching under conditions when the flow of sucrose solution in any one feeder is below $1 \mu\text{l}/\text{min}$. The analysis of matching behavior will be used as a tool to address questions of the honeybee's foraging ecology from the point of view of learning and memory mechanisms. The central aim is to uncover internal automatic learning and memory processes which are designed by ultimate mechanisms in evolutionary terms to guide quick decisions in a food patch offering several alternatives with different amounts of reward.

Methods

A single freely flying bee was trained to collect from four artificial feeders (Fig. 1). The reward per visit was typically less than $2 \mu\text{l}$ of a $2M$ sucrose solution (ss). The bee, therefore, had to make many visits (more than 30) to fill its crop before returning to the hive. The sucrose solution offered by each feeder was controlled by a computer and could be set to any flow rate between 0.02 and $1 \mu\text{l}/\text{min}$. To avoid overflow (volumes larger than $2 \mu\text{l}$) the increment was effectively stored by the computer and released only when the bee started sucking. An infrared microbeam (Fig. 1 EB) detected the experimental bee when it entered the tube leading to the capillary (FC). An array of eight diodes (DA) surrounding the feeding capillary detected the proboscis of the bee when it was stuck into the capillary to search for sucrose solution, and monitored the meniscus of the sucrose solution. The signals from the microbeam at the entry and the diode array were read by the computer and were used to determine the arrival and departure time of the bee in the tube before and after sucking, and the sucking time. The diode array allowed a precise ($\pm 0.02 \mu\text{l}$) determination

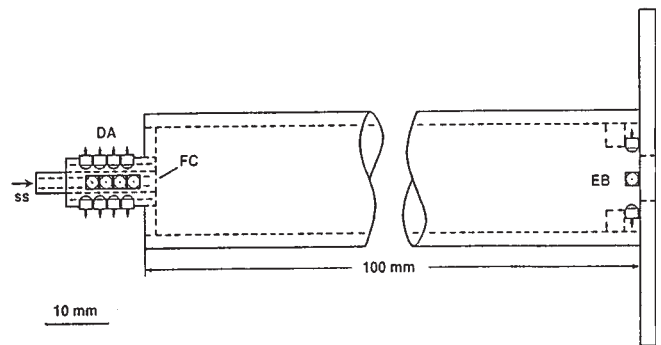

Fig. 1. Schematic drawing of an electronic feeder. EB: entrance beam, FC: feeding capillary, DA: diode array, SS: sucrose solution. The bee enters the tube from the right through a hole in a colored filter glass (Schott filters)

of the sucrose solution offered to the bee under natural conditions at temperatures ranging between 10° and 35° C. The sucrose solution was delivered to the capillary by a 10-ccm syringe driven by a stepping motor which was activated by the computer. The flow rates given in the text refer to continuous provisions of sucrose only during the period in which the experimental bee was working in the patch. The sucrose solution did not accumulate during periods when the bee returned to the hive.

Experimental design. All experiments reported here were carried out in August and September, when natural competition was low and colony conditions were stable, in order to obtain comparable data from different experimental bees. Seven different experimental arrangements were used, with different flow rates to the four feeders combined with different colors or odors in vertical or horizontal arrangements (Table 1).

Data analysis. All data was stored in real time on hard disc and was evaluated using several Pascal programs. These allowed for the extraction of the relevant parameters for data analysis and statistical tests (two-tailed *t*-test, and two-tailed Wilcoxon test; $P < 0.05$ is considered to indicate statistically significant differences).

Results

General observations

The foraging behavior of a single experimental bee flying in the "patch" of four feeders depends strongly on the flow rate of sucrose solution in each of the feeders and in all four feeders together. If the overall flow rate in the patch is below $0.4 \mu\text{l}/\text{min}$, bees tend to give up searching and return to the hive. At an overall flow rate of 0.5 – $2 \mu\text{l}/\text{min}$, the experimental bee stays in the patch. If the flow rate of a single feeder exceeds $1 \mu\text{l}/\text{min}$, the bee visits only this high-reward feeder and ignores the three alternatives. Thus the bee maximizes and shows flower constancy with respect to this high-reward feeder.

In all the experiments reported here the total flow rate varied between 0.56 and $2 \mu\text{l}/\text{min}$, and the flow rate of any one feeder never exceeded $0.5 \mu\text{l}/\text{min}$ (Table 1). As a consequence, the experimental bee visited all feeders. If the flow rate of a single feeder was set to zero the bee continued visiting this feeder nearly as frequently as a low-reward feeder for at least one foraging bout

Table 1. Summary of all experiments**A. Vertical arrangements***Experiment 1: equal flow rate experiment (1111 vertical)*

Flow rate	0.5	0.5	0.5	0.5 µl/min
Flow rate ratio	1	1	1	1
Color	AL	AL	AL	AL
Odor	—	—	—	—
Distance	35	35	35	35 cm

N: 4 test bees; n: 1031 choices; year: 1988

Experiment 2: equal flow rate experiment (1111 vertical)

Flow rate	0.5	0.5	0.5	0.5 µl/min
Flow rate ratio	1	1	1	1
Color	UG1	BG24	AL	GG495
Odor	—	—	—	—
Distance	35	35	35	35 cm

N: 6 test bees; n: 2284 choices; year: 1989

Experiment 3: different flow rate experiment (1228 vertical)

Flow rate	0.0625	0.125	0.125	0.5 µl/min
Flow rate ratio	1	2	2	8
Color	UG1	BG24	AL	GG495
Odor	—	—	—	—
Distance	35	35	35	35 cm

N: 3 test bees; n: 588 choices; year: 1988

Experiment 4: different flow rate experiment (1248 vertical)

Flow rate	0.0625	0.125	0.25	0.5 µl/min
Flow rate ratio	1	2	4	8
Color	UG1	BG24	AL	GG495
Odor	—	—	—	—
Distance	35	35	35	35 cm

N: 8 test bees; n: 3537 choices; year: 1989

B. Horizontal Arrangements*Experiment 5: equal flow rate experiment (horizontal control)*

Flow rate	0.25	0.25	0.25	0.25 µl/min
Flow rate ratio	1	1	1	1
Color	BG28	BG28	BG28	BG28
Odor	—	—	—	—
Distance	100	100	100	100 cm

N: 4 test bees; n: 2454 choices; year: 1991

Experiment 6: different flow rate experiment (1228 horizontal)

Flow rate	0.0625	0.125	0.125	0.5 µl/min
Flow rate ratio	1	2	2	8
Color	BG28	BG28	BG28	BG28
Odor	geraniol	orange	orange	geraniol
Distance	100	100	100	100 cm

N: 6 test bees; n: 1567 choices; year: 1991

Experiment 7: horizontal dual choice experiment (18 horizontal)

Flow rate	0.0625	—	—	0.5 µl/min
Flow rate ratio	1	—	—	8
Color	BG28	—	—	BG28
Odor	—	—	—	—
Distance	100	—	—	100 cm

N: 1 test bee; n: 345 choices; year: 1991

Italicized phrases are used in the text to distinguish particular experiments

before it reduced visitation to a very low level. The ratio of the highest to the lowest flow rate was set to a maximum of 8:1. Under these conditions the feeder with the lowest flow rate was still visited frequently. Higher ratios were not studied systematically.

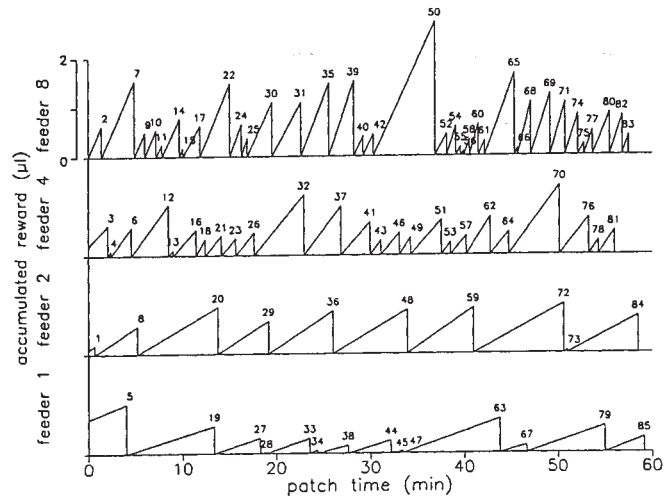

Fig. 2. Sequence of visits of an experimental bee at the four feeders (1, 2, 4, 8) during one foraging bout which lasted 57 min (*abscissa*). The successive visits are indicated by *ascending numbers*. The flow rates of sucrose solution in the four feeders are different: 0.0625 µl/min in feeder 1, 0.125 µl/min in feeder 2, 0.25 µl/min in feeder 4, 0.5 µl/min in feeder 8. Thus, the ratios of the flow rates are 1:2:4:8, coinciding with the number tags of the respective feeders. The accumulation of the sucrose solution in each feeder during the inter-visit intervals is indicated by the *rising slopes of the curves*, which are different for the four feeders because of their different flow rates. The bee imbibes all of the accumulated sucrose solution at any visit indicated by the *reset of the rising slope*. The effective reward at each visit can be read from the *height of the function* at each reset point. Note that even at the high reward feeders (feeders 4 and 8) the effective amount of reward may be very small if the time elapsing after the last visit is very short

A typical pattern of visits to the four feeders during one foraging bout is shown in Fig. 2. In this experiment the total flow rate was 0.9375 µl/min, with ratios of 1:2:4:8 (absolute flow rates 0.0625, 0.125, 0.25, 0.5 µl/min). It is obvious that the higher-reward feeders are visited more frequently than the lower-reward feeders. One can also see that the amount of reward experienced at each visit varies greatly and depends not only on the sucrose solution accumulated in the feeder according to the flow rate of the particular feeder, but also on the interval between two successive visits. Consequently, each feeder may provide high- and low-reward amounts at any visit, depending on its intrinsic flow rate and the choice behavior of the bee. Usually the visits follow each other quickly at a rate of 0.5–1.4 per minute (Fig. 2). More than half of the time is spent within the feeder, and most consecutive visits take place at intervals of less than 16 s (Fig. 3). Bees suck sucrose solution at a rate of approximately 1 µl/sec (Nunez 1970). As a result, the experimental bee should collect the accumulated sucrose solution within a few seconds, even in cases where relatively large amounts of sucrose solution (> 2 µl) are available. This means that most of the time spent within the feeder is “handling time” in which the bee probes and searches for additional reward. Since bees fly within the patch with a speed of 1–2 m/sec and the distances between the feeders are well below 2 m, the bees could easily manage to visit the feeders at shorter intervals.

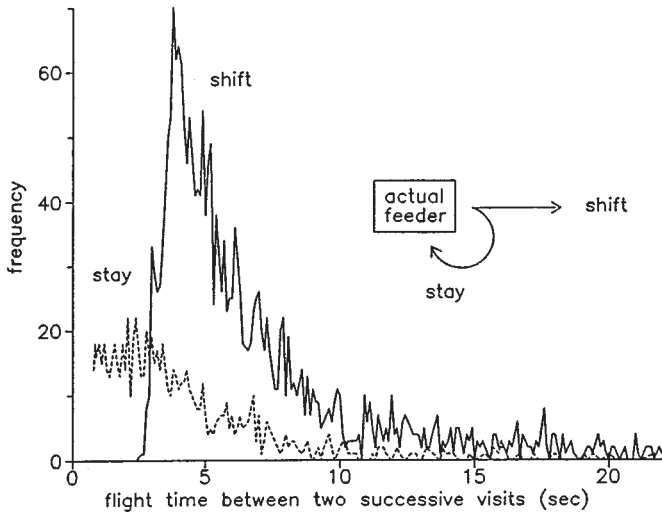

Fig. 3. Frequency distribution of "stay" and "shift" flights dependent on the time between departure from a feeder ("actual feeder") and arrival at the next feeder. The first few seconds are dominated by stay flights, while shift flights show a clear maximum at about 4 s (stay: $n=934$, shift: $n=2603$ decisions of eight animals)

Therefore, the flight time between the feeders is an adaptation to the particular parameters of the patch and can be evaluated as decision time. Handling time and decision time will be analyzed below.

"Stay" and "shift" flights

Any time the experimental bee leaves a feeder (henceforth called the "actual feeder") it may either return to that feeder ("stay" flight), or choose one of the three alternative feeders ("shift" flight). The probability of stay and shift flights depends greatly on the amount of sucrose solution reward experienced at the actual feeder. The time dependencies of the two types differ considera-

bly (Fig. 3). The first 3 s after departing from the actual feeder are dominated by stay flights. Shift flights appear after a latency of 3 s, and reach a probability maximum at about 4 s after departure. When bees leave a feeder in the vertical arrangement they usually fly off in a straight line for a certain distance and then turn around to face the vertical feeder patch. From that point the distance to any one of the four feeders is very much the same. Similar time courses for stay and shift flights were found for horizontally arranged feeders. Therefore, the temporal dynamics of the stay and shift flights reflect a difference in the choice process rather than a difference in the flight paths performed during stay and shift flights.

Matching behavior

Bees choose a high-reward feeder more frequently than a low-reward feeder (Fig. 2). The matching between the amount of reward obtained and the behavior of the bee directed towards the feeders will be analyzed along two lines. The choice proportions at the four feeders are referred to as "event matching" because they reflect the matching of the probability of events (choice after a stay or shift flight) with the reward conditions. The matching of time-linked parameters requiring energy investment (e.g. handling time, lick time and flight time) with the reward conditions are referred to as "time matching".

Overall event matching

To test how the bee's choice behavior corresponds to the average amount of reward, the data from patches with different reward rates were compared with data from experiments with equal reward rates. Figure 4a shows the choice proportions of both stay and shift flights towards four vertically arranged, equally rewarding feeders (*experiment 2: 1111 vertical*). Although the

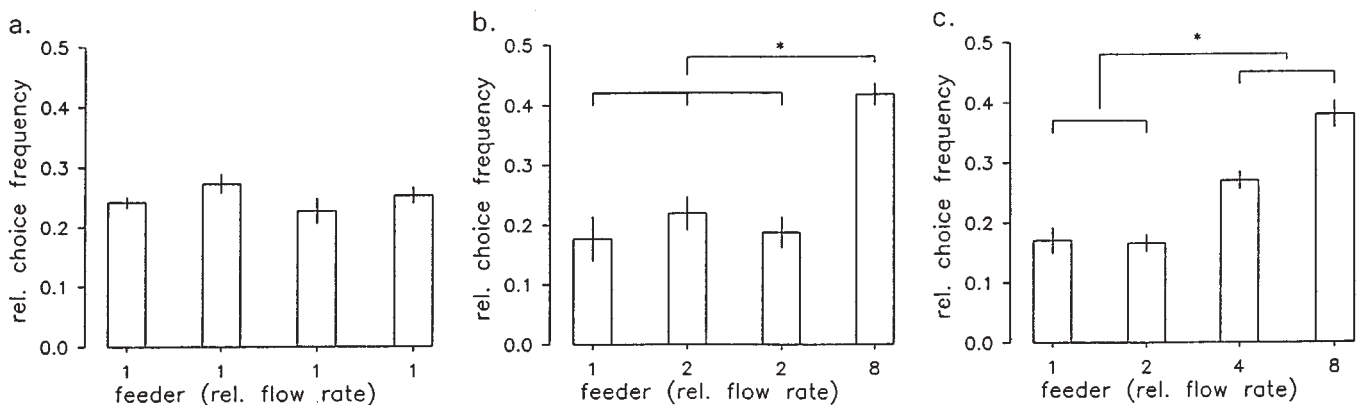

Fig. 4a. Overall event matching (stay and shift flights) in *experiment 2: 1111 vertical*. Each feeder provides equal flow rates ($0.5 \mu\text{l}/\text{min}/\text{feeder}$, decisions of 6 bees, $n=2284$; mean values, error bars: standard error). Each feeder is marked with a different color: feeder 1=white AL, Aluminium, feeder 2=blue-green, GG495, feeder 3=violet, BG24 and feeder 4=ultra-violet, UG1. **b** Overall event matching (stay and shift flights) in *experiment 3: 1228 vertical*. The four feeders have 3 different flow rates: feeder 1= $0.0625 \mu\text{l}/\text{min}$,

feeder 2= $0.125 \mu\text{l}/\text{min}$ and feeder 8= $0.5 \mu\text{l}/\text{min}$. Ratios 1:2:2:8. ($n=588$ decisions of three bees). As in Fig. 4a the four feeders are marked with different colors. **c** Overall event matching (stay and shift flights) in *experiment 4: 1248 vertical*. The four feeders have 4 different reward rates: feeder 1= $0.0625 \mu\text{l}/\text{min}$, feeder 2= $0.125 \mu\text{l}/\text{min}$, feeder 4= $0.25 \mu\text{l}/\text{min}$, feeder 8= $0.5 \mu\text{l}/\text{min}$. Ratios 1:2:4:8. ($n=3537$ decisions of 8 bees). As in Fig. 4a, b the four feeders are marked with different colors

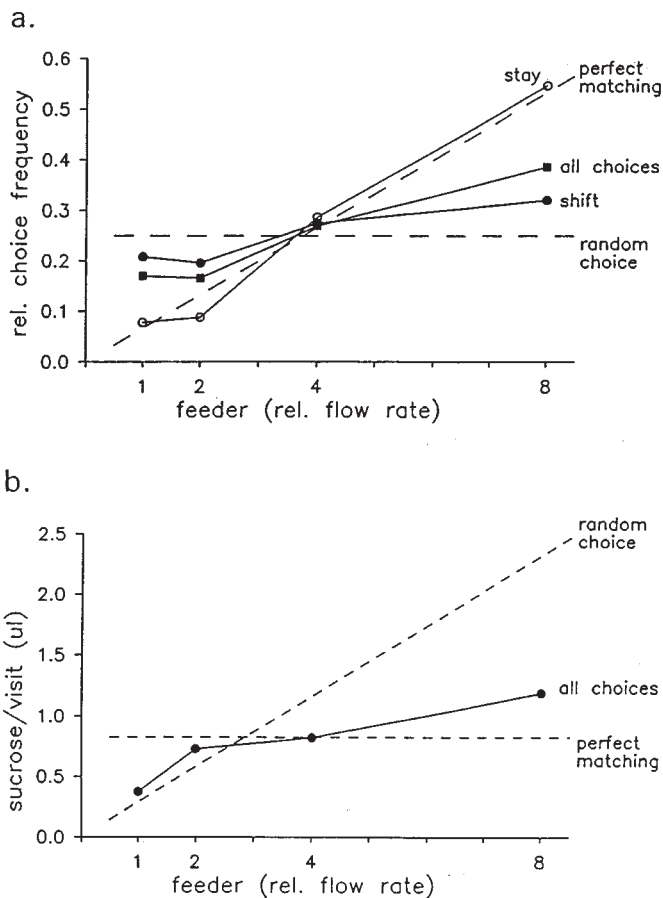

Fig. 5. a Event matching in *experiment 4: 1248 vertical* (solid lines). The dashed lines give two theoretical extremes of choice strategy: perfect matching and random choice. The curve marked by filled squares (all choices) gives the results for all choices; the curves marked by circles analyse the choices into stay (open circles) and shift (filled circles) flights. Number of all choices $n = 3537$, of 8 bees. b Average amount of reward (μl sucrose solution) per visit at the four feeders compared to random choice and perfect matching (dashed lines)

feeders were marked with highly distinguishable color signals in this particular experiment, the bees developed no feeder constancy but chose the four feeders with equal frequency. The same equal choice proportions were found in other experiments: *experiment 1 (1111 vertical)*; here all feeders were marked with the same white color, AL), and *experiment 5 (1111 horizontal)*; here all feeders were marked with the same blue color, BG28; see Table 1 for explanation). These results indicate that feeders with the same flow rates of sucrose solution were chosen equally frequently, irrespective of whether the feeders were marked with the same or different colors, and thus, were distinguishable either both by color and location, or by location alone.

The relative choice frequencies for feeders with different flow rates are plotted in Fig. 4b, c. The highest-reward feeder 8 is visited significantly more frequently than the other three alternatives (t -test, $P < 0.05$). Note that the two equal flow rates in Fig. 4b allow an estimate of the experimental deviations. The same choice distribu-

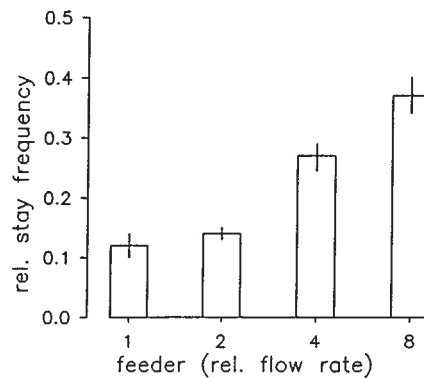

Fig. 6. Relative stay frequency in *experiment 4: 1248 vertical*. The relative proportions of stay flights are expressed by setting the sum of stay and shift flights to 1 for each feeder separately. ($n = 3537$ number of decisions of eight bees; mean values, error bars: standard error)

tion and deviations apply for an experiment with horizontally arranged feeders (*experiment 6: 1228 horizontal*). In the case of flow proportions 1:2:4:8 (Fig. 4c), the choice frequencies for the two high-reward feeders 4 and 8 are significantly higher than for the low-reward feeders 1 and 2. In all experiments the lowest-reward feeder 1 is chosen as frequently as the second lowest-reward feeder, and the highest-reward feeder 8 only slightly more frequently than feeder 4 with half the flow rate.

What are the rules behind this matching behavior? Two theoretical cases of "matching" are plotted in Fig. 5a, b for a comparison with the experimental data: perfect matching, and random choice. If all choices (stay and shift flights) are considered there is obviously no linear correlation between flow rate and choice frequency. Compared to a perfect linear matching, the lowest reward feeder 1 is always visited more frequently and the highest reward feeder 8 is visited less frequently (Fig. 5a). Consequently, the bee collects less sucrose solution per visit at feeder 1 and more sucrose solution per visit at feeder 8 than expected for perfect matching (Fig. 5b).

In the case of perfect matching the animal would apply a choice strategy which would lead to an equal amount of reward extraction at each visit to any of the four feeders. Such a strategy could come about by either a stochastic process, where the means show the perfect matching, or by a systematic search strategy. Similarly, in the case of random choice the animal might apply a true random choice behavior or it could visit all feeders equally frequently, thus applying a systematic choice strategy. The analysis presented below aims to identify the systematic and stochastic components of the choice behavior. For this reason it is necessary to break down the choice behavior into its different event and time components, and to analyze more closely what the animal has learned about the four feeders in the patch. The data from *experiment 4 (1248 vertical)* is used to elucidate the mechanisms of matching. If not otherwise stated, all results described below refer to this kind of experiment.

Table 2. Dependence of the relative stay frequency after visiting the actual feeder on the reward sequence

	Reward "actual" feeder	
	Low	High
Reward "last" feeder		
Low	9.95% \pm 2.7 <i>n</i> = 693	31.7% \pm 3.1 <i>n</i> = 1076
High	5.4% \pm 3.3 <i>n</i> = 721	24.8% \pm 2.4 <i>n</i> = 769

n = 3537, 8 bees; stay + shift flights = 100%, low < 0.4 μ l, high > 0.4 μ l

"Last low - actual high" versus "last high - actual high" is significant ($P < 0.05$, paired *t*-test, choice frequencies with S.D.)

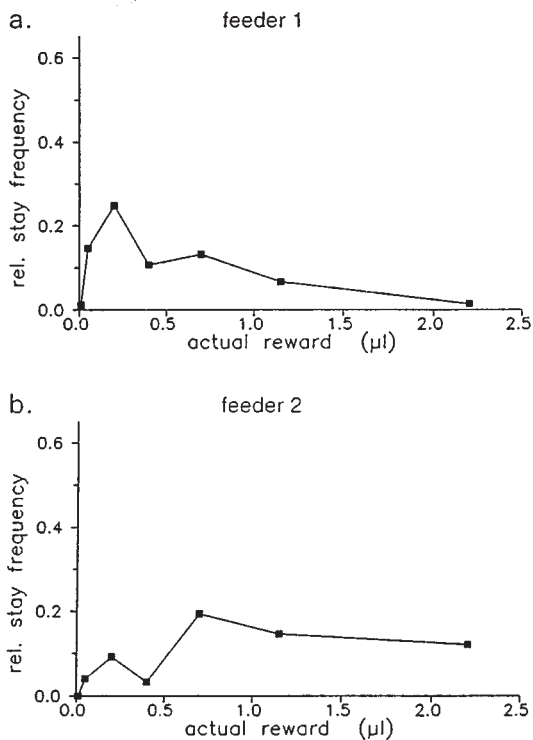

Fig. 7a-d. The relative stay frequency as a function of actual reward during the last visit to each particular feeder. Relative proportions of stay flights are expressed as in Fig. 6 by setting the sum of stay and shift flights to 1 at any sample point. Seven sample points along the continuum of actual reward (*abscissa*) are chosen, each

Analysis of stay and shift behavior

If the choice frequencies at the four feeders are plotted separately for the stay and shift flights, almost perfect matching is observed for the stay flights. Consequently, choices resulting from shift flights match even less than the total number of choices (Fig. 5a). This striking result becomes even more clear if the proportions of stay flights are expressed as a fraction of the sum of stay and shift flights at each feeder separately (Fig. 6). At the highest reward feeder 8, more than one-third of all choices result from stay flights although the short intervals between

Table 3. Flight time of stay flights after visiting the actual feeder

	Reward "actual" feeder	
	Low	High
Reward "last" feeder		
Low	6.0 s \pm 0.7 <i>n</i> = 231	4.3 s \pm 0.6 <i>n</i> = 253
High	6.4 s \pm 0.8 <i>n</i> = 264	5.0 s \pm 0.7 <i>n</i> = 186

n = 934, 8 bees; low < 0.4 μ l, high > 0.4 μ l

"Last low - actual high" versus "last high - actual low" is significant ($P < 0.05$, paired *t*-test, average flight time with S.D.)

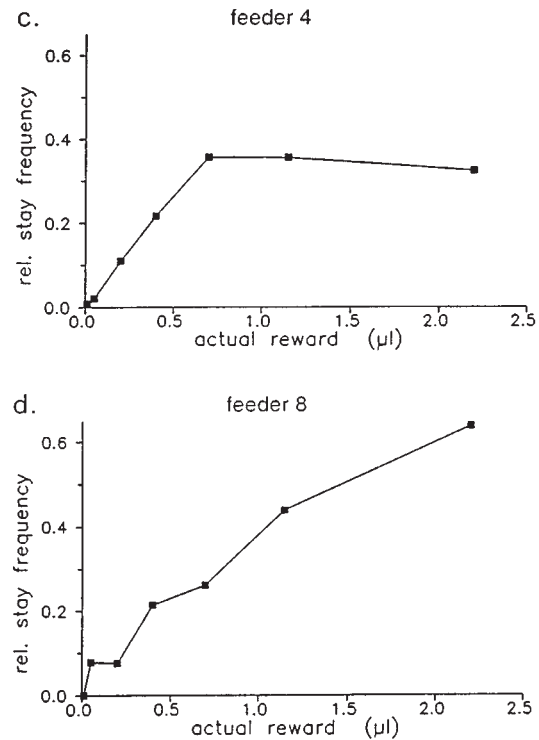

representing more than 100 decisions. For feeder 1 the relative stay frequency in the range < 0.3 μ l is significantly different ($P < 0.05$, Wilcoxon test) from the relative stay frequency at feeder 8 in the range > 0.4 μ l and from the relative stay frequency at feeder 8 in the range < 0.3 μ l

two successive visits at the same feeder lead to very little if any reward during the second visit. For experiment 3 (1228 vertical) stay flights at feeder 8 include half of all choices (51%) at this feeder (not shown). For the dual choice experiment 7, there is an exact linear matching between stay flights and reward ratios (not shown). Due to the fact that, in contrast to multiple choice experiments, there is only one alternative in experiment 7, no difference in the number of shift flights is observed. It is tempting to conclude that the amount of reward experienced during the last visit determines the probability of stay flights. We therefore tested whether the probabili-

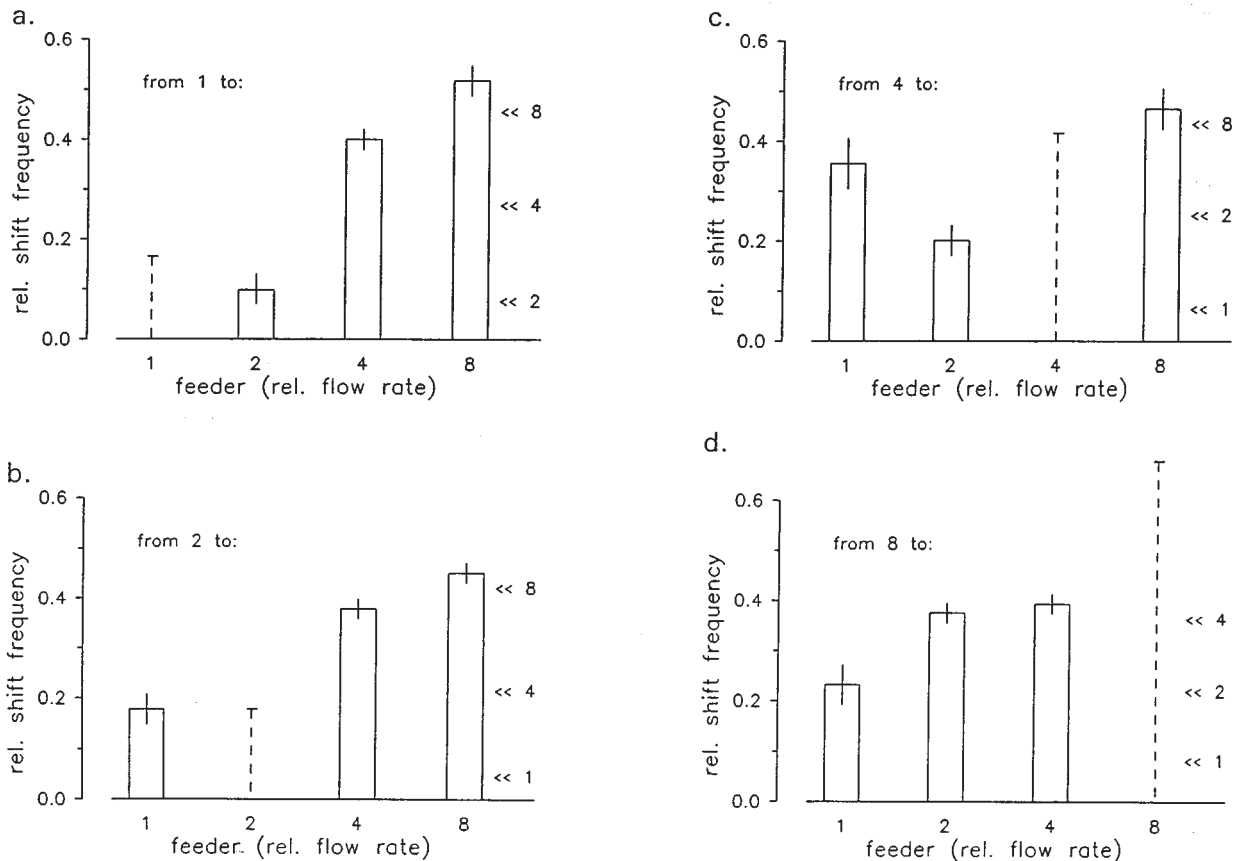

Fig. 8a-d. The relative frequency of shift flight plotted with respect to the last visited feeder (dashed bars). The same series of experiments are evaluated as in Fig. 7, which are of the type *experiment 4: 1248 vertical*. Visiting high-reward feeders leads to reduced discrimination of lower-reward feeders, while visiting low-reward feeders leads to nearly linear matching (high discrimination). The levels

of the *dashed bars* represent the proportions of stay flights at the last-visited feeder. Hypothetical choice levels for perfect matching with the reward situation at the three alternative feeders are marked by *arrowheads*. Mean values, *error bars*: standard error, $n = 3537$ visits, of 8 bees

ty of stay flights is determined by the reward experience during the last visit only, or also by earlier visits. Table 2 shows that the frequency of stay flights depends not only on the last visit but also on the change in the amount of reward during two successive visits. If a high reward follows a low reward, stay flights are more frequent; if a low reward follows a high reward, shift flights are more frequent. Table 3 gives the effects of changes in the amount of reward during two successive visits on the intervals for stay flights. If the two rewards are the same (both low or high) then the stay flights will last for an average 5.5 s. If a low reward follows a high reward stay flights are longer; if a high reward follows a low reward stay flights are shorter. The flight time of shift flights with respect to the last-visited flower shows no dependence on the reward sequence (for analysis of target-specific flight time see below).

Next we asked whether it matters at which feeder a certain amount of sucrose solution reward is experienced. Such an analysis raises the question of whether the experimental bee learns to expect a certain amount of reward at each of the four feeders. The analysis is based on the fact that the probability of stay flights rises with the amount of reward during the visit preceding

the shift or stay flight (Fig. 7). Indeed, the function of relative stay flight frequency plotted against actual reward is different for each of the four feeders. Only small amounts of reward are needed at the lowest-reward feeder 1 to initiate the highest relative frequency of stay flights, whereas at the highest-reward feeder 8 the function rises continuously. The other feeders have functions in between.

Finally the feeder-dependent differences of stay flights also suggest feeder-dependent choices for shift flights. Therefore, the relative choice frequencies for the four feeders were plotted with respect to the feeder visited last (Fig. 8). For the low-reward feeders 1 and 2 the matching is almost linear, whereas little matching is found for the other two feeders. In general, high actual rewards lead to a high proportion of stay flights and also to poor discrimination between the lower reward feeders.

It is concluded from these results that the bees have developed specific expectations about the reward conditions at the four feeders. Their behavior towards and at each of the four feeders may, therefore, be reflected also in graded components of their foraging behavior, the question which will be examined next.

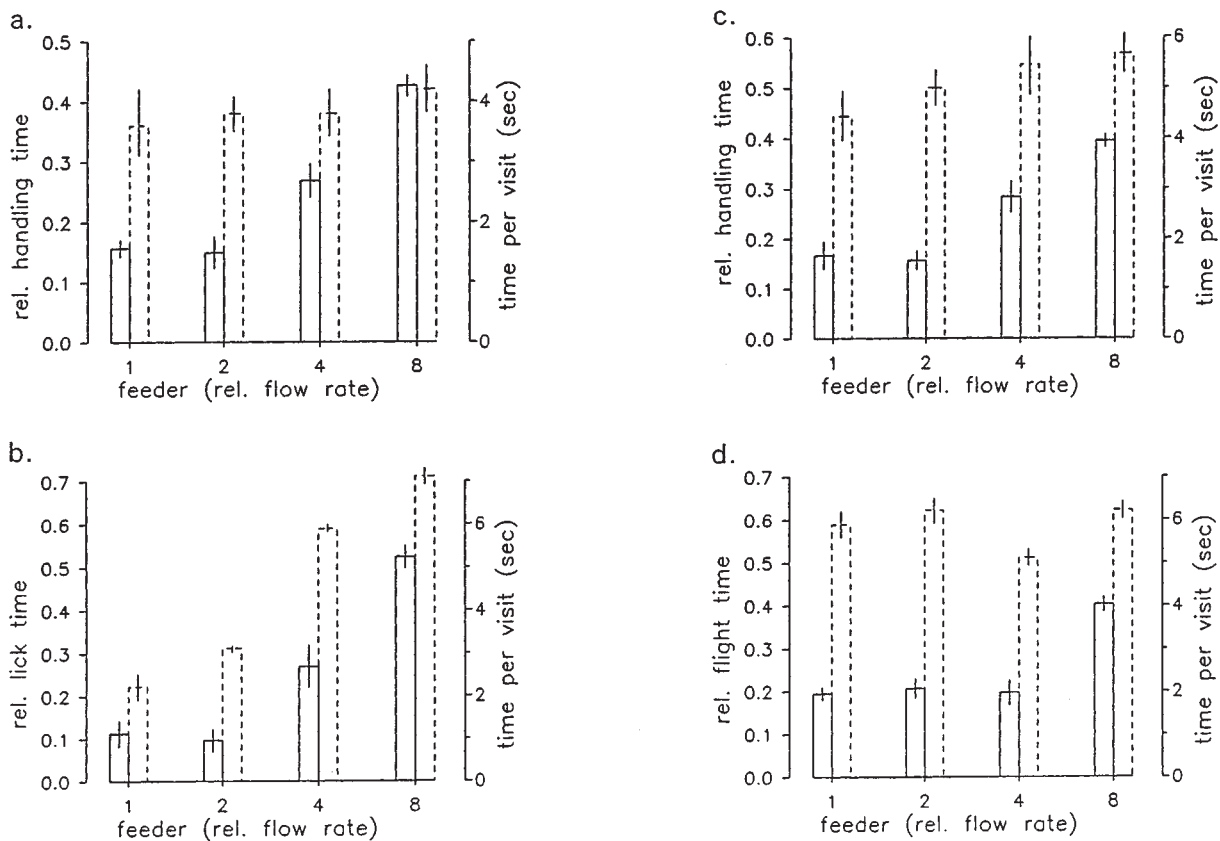

Fig. 9a–d. Matching of graded behavioral parameters with the flow rate of sucrose solution in experiment 4: 1248 vertical. a The bars with full lines plot the cumulative handling time before sucking, in all visits to each of the 4 feeders. The bars with dashed lines give the average handling time before sucking per visit. Number of visits $n=3537$ of eight bees, mean values, error bars: standard error. b The bars with full lines give the cumulative licking time during all visits to each of the 4 feeders, and the bars with dotted

lines the average licking time per visit. c The bars with full lines give the cumulative handling time after licking (sitting, running in the tube) during all visits to the 4 feeders, and the bars with dashed lines the average handling time per visit. d The bars with full lines give the cumulative flight time between two successive visits for all flight times from the indicated feeder and any next feeder, and the bars with dotted lines the average flight time after a visit to the indicated feeder

Time matching

If matching behavior reflects an optimization process for energy and information gathering, it is to be expected that not only choice frequency (events) will be matched with the expected reward but also the overall time the animal spends at the different food sources. Therefore, the following behavioral parameters were tested: (1) the handling time before sucking, (2) the lick time, (3) the handling time after sucking and (4) the flight intervals between the successive choices. Figure 9a–d (bars with solid lines) shows that these behavioral parameters lead to a similar proportional rise with the flow rate. However, if the four time-related behavioral components are not expressed as cumulative measures for each of the four feeders, but plotted as median values per visit (Fig. 9, bars with dashed lines), no significant correlation with the reward proportions is seen. This indicates the dominance of the choice process over time-related optimization, i.e. that the behavioral events contain the information about the matching behavior of the bee, but that the average time-related components, with the exception

of the lick time, do not change significantly with the reward proportions.

The lick time considerably exceeds the actual time needed to suck the offered sucrose solution and thus might be an indicator of the incentive to probe for more sucrose solution (Table 4). A shift from low to high reward over two successive visits extends licking time moderately, when compared to no shift, while a shift from low to high reward induces long licking. The result applies to both stay and shift flights following departure from the last feeder. This indicates a reward expectation resulting from the recent experience at the last feeder.

Temporal dynamics of choice behavior

The different time courses for stay and shift flights (Fig. 3) and the different probabilities of stay and shift flights (Fig. 7) after visits to any of the four feeders in experiment 4 (1248 vertical) should make the choice proportions of the four feeders dependent on the time interval following the last visit. Figure 10 shows that the

Table 4. Lick time at the actual feeder of 8 bees

		Reward "actual" feeder	
		Low	High
Reward "last" feeder			
Low		7.1 s \pm 0.8 n = 693	14.9 s \pm 0.9 n = 1076
High		7.0 s \pm 0.6 n = 721	18.5 s \pm 0.8 n = 769

n = 3537; low < 0.4 μ l, high > 0.4 μ l

"Last low – actual high" versus "last high – actual high" is significant ($P < 0.05$, paired *t*-test)

choice frequencies of the four feeders change with the flight time between two successive visits, and that the time course differs drastically for all four feeders. Consequently, the mean choice proportions during three major time intervals for the four feeders is highly time-dependent. At very short intervals (< 3 s) the high-reward feeders 8 and 4 attract most choices. This reflects the almost perfect matching found for the stay flights (Fig. 5a) which dominate this short time interval. At longer intervals (4–7 s), the higher-reward feeders 4 and 8 become less attractive, whereas feeders 1 and 2 become more attractive. Most importantly, feeder 4, which offers only half as much sucrose solution as feeder 8, is chosen most frequently at longer intervals (8–22 s). When the experimental bee returns from the hive the average choice behavior during the first 5 min shows the same proportions as were found for the overall event matching (Fig. 5a).

Decision time towards a feeder

The temporal dynamics of the flight time during shift flights between two visits was more closely examined for the arrangement of *experiment 6: 1228 horizontal*, because under these conditions bees choose the three feeders 1, 2 and 2 with equal frequency, and feeder 8 is chosen significantly more frequently. Figure 4b shows such a choice distribution, but for the corresponding vertical arrangement (*experiment 3: 1228 vertical*). On the basis of these choice frequencies, the 12 different transitions of shift flights between the four feeders can be separated into two classes, those directed towards feeder 8, and those directed towards the other three feeders 1, 2, 2 (Fig. 11a). The flight times during these two kinds of transitions were analyzed according to whether the animal had experienced a low or a high reward during the last visit, i.e. the visit preceding the shift flight. All rewards below 0.4 μ l were assigned as low rewards, and all rewards above 0.4 μ l were assigned as high rewards, irrespective of the feeder at which this last reward was experienced. The shift flights are fast (median 5.8 – 0.6 + 1.8 s) if they are directed towards the feeders 1, 2, 2 and do not differ for high or low last rewards (Fig. 11b). The same fast time course with the same median value is found for flights towards feeder 8 if a low

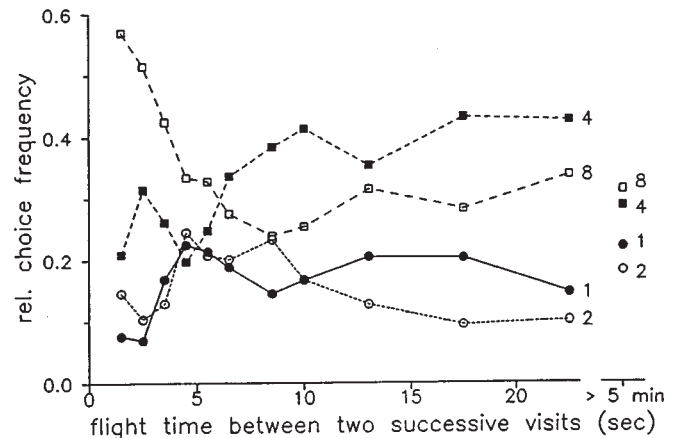

Fig. 10. Temporal dynamics of the choice behaviour dependent on the flight time between departure and arrival at the feeders in *experiment 4: 1248 vertical*. The numbers 1, 2, 4 and 8 at the curves indicate the choice proportions for the respective feeder. Note the reduction in choice of feeders 8 and 2 and the increase in choice of feeders 1 and 4 at longer intervals (8–22 s). Average choice proportions during the first 5 min of each bout, i.e. the first decisions after the bee returned from the hive are marked at > 5 min (n = 818 decisions of 8 bees) Feeder 1: 22.4% \pm 3.4, feeder 2: 18.2% \pm 2.7, feeder 4: 28.5% \pm 1.4, feeder 8: 32.1% \pm 1.9

reward had been experienced just before (Fig. 11c). However, if the last reward had been unexpectedly high at one of the usually low feeders 1, 2 or 2, then the flight towards 8 lasted significantly longer (median value 9.9 – 1.4 + 0.3 s). Corresponding results were found in *experiment 7: 18 horizontal*. In *experiment 4: 1248 vertical*, such an effect is found for both feeder 4 and feeder 8, but less pronounced for feeder 8. We might call this result a surprise effect and take it as additional evidence that the animal developed a feeder-specific expectation about the amount of reward.

The preceding section clearly demonstrated that the choice process is not stochastic but is rather dominated by specific rules which are based on memories resulting from the experience at the four feeders.

Modeling

An understanding of the informational processes guiding foraging behavior may be facilitated by a modeling approach. Such an approach should take into account that bees very quickly and effectively learn the features of the food site (the conditioned stimuli: location, odor, color, etc.) and the properties of the reward (the strength of the unconditioned stimulus: amount of sucrose solution). The moment-to-moment decisions during foraging can be adequately described as a sequence of trials of an acquisition process in an associative conditioning situation in which the various conditioned stimuli (CS) become predictive for the unconditioned stimulus (US). The probability of a conditioned response to the CS reflects the strength of the associative memory, and thus, the reliability of the expectation that the US follows the

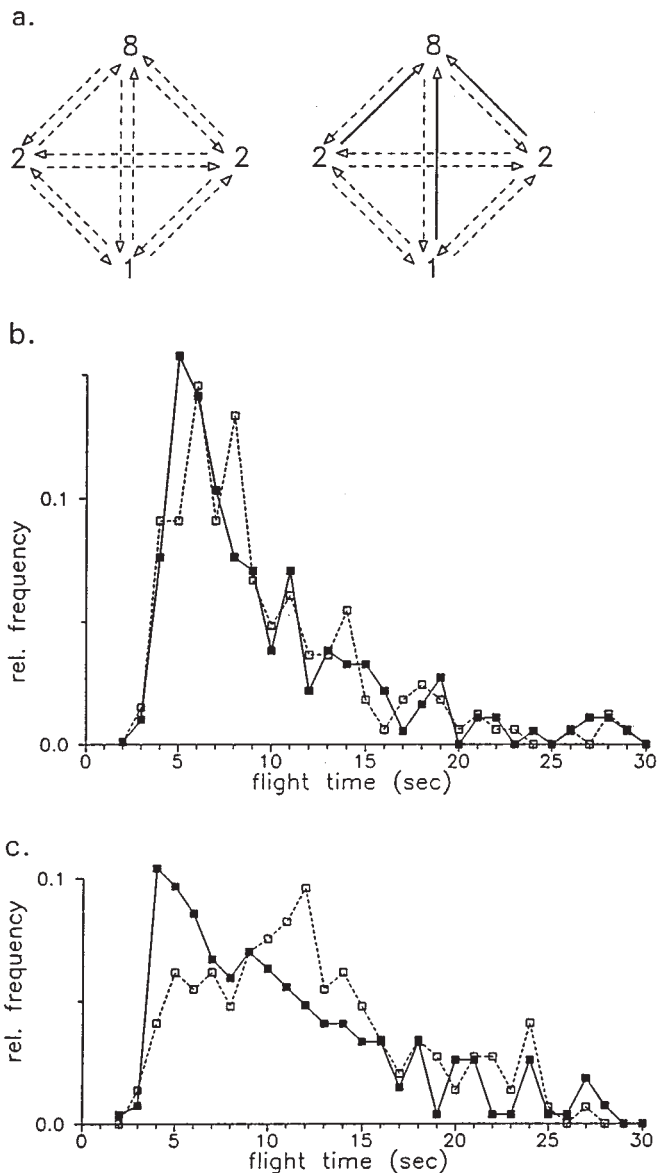

Fig. 11 a–c. The experimental bee can perform 12 different kinds of shift flights between the 4 feeders (arrows in a left). These shift flights, in *experiment 6: 1228 horizontal*, are divided into two categories, those directed towards the high rewarded feeder 8 (full lines), those directed towards the other feeders 1, 2, 2 (dashed lines). b, c frequency distribution of flight time following a low reward (<math><0.4 \mu\text{l}</math>, full lines) and a high reward (>math>>0.4 \mu\text{l}</math>, dotted lines). b gives the shift flights towards feeders 1, 2, 2, c the shift flights towards feeder 8. The difference between the median values is significant ($P < 0.01$, Wilcoxon test), and the single values at 5.6 and 12 s are also significantly different ($P < 0.05$)

CS. Until the maximum associative strength is reached for each trial there is a difference between the expected reward and the actually experienced reward which influences the updating of the memory, resulting in an altered expectation for the next trial.

Such an acquisition process has been described by models which are based on a general assumption about associative learning, the difference rule (Rescorla and Wagner 1972; Sutton and Barto 1981).

Here we use the Eq. 1 of Rescorla and Wagner (1972), because their model has been successfully applied to the description of behavioral learning phenomena, especially the formulation of the animal's expectancy, and feeder-specific expectations were found to guide the choice behavior of the bee.

$$\Delta V_i = \alpha_i \beta_1 (\lambda_1 - \Sigma V_s) \quad (1)$$

where ΔV_i is the change in the associative strength between the i th CS element and the US, α_i is the learning rate parameter of CS $_i$ and β_1 is the learning rate parameter of the US, λ_1 is the maximum possible level of associative strength between CS and US determined by the US intensity and ΣV_s is the sum of associative strengths between all CS elements s and the US in a particular learning trial. The equation describes an asymptotic acquisition function with a maximum at $\alpha_i \beta_1 \lambda_1$.

In an attempt to simulate the choice behavior of the honeybee the following assumptions were made: in the experimental situation described above, (1) the CS (location, odor, color, etc.) for each of the four feeders are constant, so that the learning rate parameter for the CS α_i in Eq. 1 can be ignored; (2) the experienced US changes with successive visits at the differently rewarded feeders. Thus, λ_1 depends on the sucrose solution flow rate at each feeder and was set equal to the amount of reward λ actually obtained at each visit to a particular feeder. Because no saturating effect on the behavior could be observed within the range of rewards tested in the experimental situation, such a linear correlation seemed to be justified. The feeder-specific behavior (Fig. 7) leads to the assumption that there are feeder-specific expectancies for each of the four feeders. Consequently, with many visits to an individual feeder the expectancy approaches the corresponding mean reward rate of each feeder.

$$\Delta V_{\text{feeder}} = \beta (\lambda - \Sigma V_{\text{feeder}}) \quad (2)$$

where V_{feeder} is a feeder-specific memory updated by the actual reward λ , and where the expectancy ΣV_{feeder} is determined by the sucrose solution flow rate of each individual feeder.

If these assumptions were used to simulate the experimental data of the "1248 vertical" experiment, a linear matching (see the theoretical curves in Fig. 5) of choice proportions with the reward situation of the patch was found. This justifies the application of this learning rule in this context. However, linear matching was not found in our experiments (see Fig. 5a). Therefore, additional mechanisms have to be included in our model.

We next modified the model by applying different learning rate parameters β for the positive or negative deviations of the actual reward from the corresponding expectancies. However, this also failed to predict the non-linear matching actually found for the bee.

The analysis of the lick time, flight time and stay flights (Tables 2–4) suggests that at least the last reward influences the behavior at the actual feeder. Therefore, in a third version two different processes of memory formation were included: one related to the experience in

Table 5. Comparison between the experimental results (upper number with standard errors) and the model calculations (italic numbers) with respect to the matching proportions and the average amount of reward at the four feeders

	Feeder 1	Feeder 2	Feeder 4	Feeder 8
All choices (%)	16.98 ± 2.1 <i>17.7</i>	16.55 ± 1.4 <i>17.4</i>	27.00 ± 1.5 <i>28.0</i>	38.01 ± 2.2 <i>36.4</i>
Shift flights (%)	20.82 ± 1.6 <i>19.7</i>	19.60 ± 2.2 <i>20.7</i>	27.51 ± 1.8 <i>28.5</i>	32.05 ± 2.3 <i>31.1</i>
Stay flights (%)	7.79 ± 2.7 <i>11.3</i>	8.83 ± 3.1 <i>13.4</i>	28.72 ± 2.5 <i>26.8</i>	54.65 ± 3.3 <i>48.6</i>

The experimental results are from *experiment 4: 1248 vertical*. First row: all choices, $n=3537$; second row: shift flights, $n=2603$; last row: stay flights, $n=934$ of eight bees. The negative learning rate is fitted following the least square trend of the overall choices

the patch (Eq. 3 below) and one related to the experience at each individual feeder (Eq. 2).

$$\Delta V_{\text{patch}} = \beta(\lambda - \Sigma V_{\text{patch}}) \quad (3)$$

where V_{patch} is a feeder-independent memory and the expectancy ΣV_{patch} is determined by the mean reward rate of the patch updated by the actual reward λ .

Since ΔV_{patch} is feeder-independent, it contains information about the rewards last experienced. Therefore, it was possible to substitute λ in Eq. 2 by the momentary expectancy for the patch $\Sigma V_{\text{patch}}^*$ just updated by the actual reward.

The positive learning rate parameters were set to 0.8. Such a high learning rate was taken from empirical data. First, in instrumental color learning of freely flying bees more than 80% correct responses in dual choice tests were found after a single learning trial (Menzel 1967), and second, a probability of about 80% conditioned responses are found in classical proboscis extension reflex conditioning of olfactory stimuli (Menzel 1990). The best fit with the original data was found if the negative learning rate was set to 0.08, a value which fits the observations about the small extinction effects in classical conditioning (Menzel 1990) and operant learning of bees (e.g. Couvillon and Bitterman 1985).

The results of a model calculation of this type predict the non-linear matching, i.e. the relatively high choice proportions of feeder 1 and the relatively low choice proportions of feeder 8 compared to perfect matching:

$$\Delta V_{\text{patch}}^* = 0.8(\lambda - \Sigma V_{\text{patch}}) \quad \text{for } \lambda > \Sigma V_{\text{patch}} \quad (4a)$$

$$\Delta V_{\text{patch}}^* = 0.08(\lambda - \Sigma V_{\text{patch}}) \quad \text{for } \lambda < \Sigma V_{\text{patch}} \quad (4b)$$

$$\Delta V_{\text{feeder}} = 0.08(\Sigma V_{\text{patch}}^* - \Sigma V_{\text{feeder}}) \quad \text{for } \Sigma V_{\text{patch}}^* > \Sigma V_{\text{feeder}} \quad (5a)$$

$$\Delta V_{\text{feeder}} = 0.8(\Sigma V_{\text{patch}}^* - \Sigma V_{\text{feeder}}) \quad \text{for } \Sigma V_{\text{patch}}^* < \Sigma V_{\text{feeder}} \quad (5b)$$

In Table 5, the calculated choice proportions resulting from these model calculations are compared to the experimental data. In essence, the model assumes the joint

action of two memories, the feeder-specific and the patch-specific memories, which are updated during the acquisition process by the same rules (difference rule, Eqs. 4a–5b).

Discussion

General observations

Choice behavior of foraging animals can follow two strategies of optimization: (1) *maximizing*, or choosing exclusively the alternative with the best reward/cost ratio; (2) *matching*, or choosing more than one alternative by preferring more efficient ones to less efficient ones (Emlen 1966; MacArthur and Pianka 1966; Pyke et al. 1977; Pyke 1984). Honeybees apply both strategies. If the flow rate of sucrose solution exceeds a certain value (in the experiments 1 $\mu\text{l}/\text{min}$), the bee visits exclusively this particular food source, irrespective of whether other feeders offer comparable amounts of sucrose solution. This is the situation in which honeybees are flower-constant and which has generally been used in training experiments (Menzel 1990). Below this threshold, the bee visits several food sources within one foraging bout and matches its choice frequency to a certain extent to the flow rate of sucrose solution in the respective food sources. If the number of feeders (flowers) is high as under natural conditions, such a strategy might also result in flower constancy, because the high probability of stay flights after a high reward would bring the animal back to the micro-patch single plant with many flowers, or densely growing plants of the same species. In our experiment the number of feeders was small, and only one feeder represented each class of reward. Therefore, a stay flight unavoidably leads to a negative experience. The matching behavior under the conditions of our experiment is independent of the feeders' appearance (same or different color or odor). The only key parameter in our experiment was their different location. Thus although the experimental arrangement deviated from natural conditions it can be concluded that flower constancy in honeybees is not a general, stereotyped behavior, but rather a specific component of the optimization process which might lead to either maximizing or matching strategies depending on the properties of the feeders (flowers). Honeybees are, therefore, not as different from bumblebees (Heinrich et al. 1977; Heinrich 1979) as believed until now.

Two kinds of choices are performed by the experimental bee in our experiments, returning to the same feeder (stay flights) or choosing between the other feeders (shift flights). The current view in interpreting these two kinds of behavior is to assume a higher probability of straight flights after a low reward and a higher probability of curved flights after a higher reward (Pyke 1978; Heinrich 1979; Waddington and Heinrich 1981; Schmid-Hempel 1984, 1985). Such a view is based on random-walk arguments as they may apply to bacteria, copepods and other species with little or no learning capacity (see Pyke et al. 1977; Pyke 1984 for additional information). The results clearly indicate that bees apply site-specific memories for their choices, and thus a random-walk approach is

not applicable. This raises the question of what kind of search strategy is applied by the bee and whether there is an experimental approach that can uncover the choice process.

The matching paradigm

A straight forward application of Herrnstein's (1970) matching rule is not possible, because there is no simple linear correlation between the average amount of reward received from each feeder and the choice behavior or such graded behaviors as handling time, flight time or lick time. Rather a non-linear correlation is found which is highly time-dependent. The only parameter which rises linearly with the average amount of reward is the probability of stay flights (Fig. 5a). This is not a trivial result, as pointed out above, because the bee depletes a feeder completely at any visit and if it returns to the same feeder within a short interval it will reliably experience very little or no reward (inhibitory learning). It appears, therefore, that the rule "return to the food source after a feast" is a strong rule, not depressed by negative experience even after a large number of learning trials.

The non-linear matching observed for the shift flights may be explained by informational constraints. To gain perfect information about the flow rate of sucrose solution in each feeder the bee would have to monitor each choice and each amount of reward over long periods. In that case, the bee would have to calculate the productivity of each feeder by dividing the total gain of sucrose solution by the number of visits to each particular feeder. In contrast, a random choice or any regular scheme of equally frequent visits to each of the four feeders (dotted lines in Fig. 5a, b) would maximize the information at any visit, because the bee would always experience ratios of sucrose solution gain which are proportional to the ratios of sucrose solution flow rates. However, in that case, the bee would either reduce its energy budget by visiting the four feeders at a frequency set by the flow rate of the high-reward feeders, or it would leave excess amounts of sucrose solution in the high-reward feeders by visiting all feeders at a frequency set by the low-reward feeders. In the latter case, the bee would risk other bees discovering the high-reward feeders. Obviously, none of these mechanisms are applied by the bee. Rather the bee continuously collects information at the expense of a perfect matching, possibly by comparing an expectation about the gain of sucrose solution per visit with the amount of sucrose solution actually experienced. What kind of expectation is applied? A specific expectation for each feeder, or an average expectation of all feeders in the patch? One might argue that under the conditions of a limited memory, the compromise between maximizing net energy gain and informational gain has to be paid for by a suboptimal matching. However, if the memory is not limiting, a deviation from perfect matching needs to be explained.

Memories

There are at least two models of how matching is achieved:

(1) The probability matching model assumes separate

memories which are weighted proportionally to the quality of each food source. The moment-to-moment decisions are then exclusively determined by a stochastic process in which the weight of memory determines the probability with which a food source will be chosen (Staddon 1983). (2) The Rescorla and Wagner model (Rescorla and Wagner 1972) describes the continuous processing of actually experienced information and predicts the animal's expectation of the food on offer. Rescorla and Wagner's difference rule describes the trial-to-trial changes in the strength of the associative link between the CS (conditioned stimulus: for a foraging bee the features associated with the food source, such as its location, odor, color and shape) and the US (unconditioned stimulus: reward obtained at the food source) during associative conditioning as a process in which the associative strength between the CS and the US rises as a function of the US strength. Specifically, the model assumes that the US strength during any conditioning trial equals the difference between the expected US strength derived from earlier trials and the actually experienced US strength. After conditioning, the CS serves as a feeder-specific predictor of the US.

The results demonstrate clearly that feeder-specific memories are developed during the continuous learning process in the patch (Figs. 7, 8, 11). These results are implemented in a model calculation which is based on the difference rule of memory updating (Rescorla and Wagner 1972; Sutton and Barto 1981). If it is assumed that the choice behavior is guided exclusively by four independent feeder-specific memories, linear matching is found, contrary to the experimental data. The deviation from the experimental data can be corrected by including an additional memory that is not feeder-specific together with feeder-specific memories and weighted learning rate parameters. Memory components both feeder-specific and non-specific are indicated by the following results:

1. The lick time depends not only on the amount of reward offered by the actual feeder but also on the reward sequence (Table 4). Therefore, this behavior is partly guided by transient feeder-unspecific memory components.
2. The frequency and time course of stay behavior is explained to a very large degree as an immediate reaction to the actually experienced reward independent of the particular feeder (Tables 2 and 3).
3. Feeder specificity is expressed by the different profiles observed for shift flights, depending on the feeder last visited (Fig. 8). Very good matching is found for shift flights after visits to the low-reward feeders 1 and 2, and bad matching following departure from the high-reward feeders 4 and 8.
4. The probability of stay flights rises with the amount of sucrose solution just experienced. The functions describing these relationships are significantly different for the four feeders (Fig. 7). This result suggests feeder-specific memories.
5. The target specificity of the choice process is also indicated by the reward dependency of the flight time towards the high-reward feeders (Fig. 11). This implies a specific expectation of the mean reward at least for the lower-reward feeders, since a mismatch between mean reward and actually experienced reward only leads to a modulation of the flight time towards higher reward feeders when the bee is at a low-reward feeder. In contrast, an unexpected low reward at feeder 8 does not modulate the time course of the choice process. Consequently, if both non-feeder-specific and feeder-specific memories are included in the model calculations, the

